

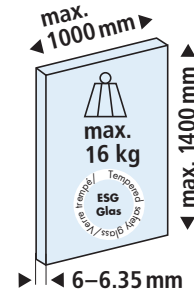

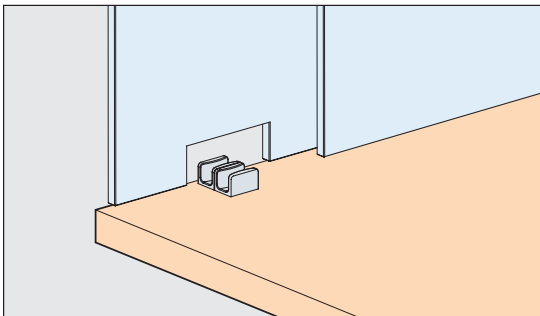

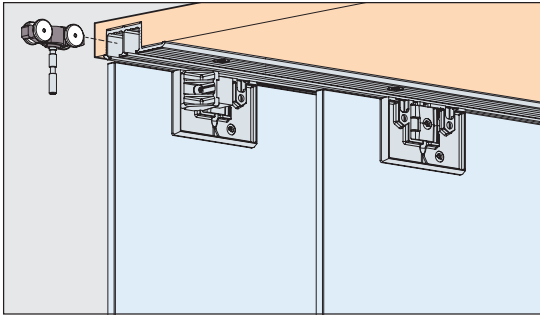

Montageanleitung Mounting instructions Instructions de montage

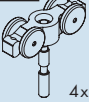

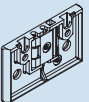
Garnituren / Sets / Garnitures

2 Türen Doors Portes		No. 053.3313.071	
	4x		2x
	4x		2x
	1x		

Zubehör / Accessories / Accessoires

	Gr./Size	Art. No.
E Doppelaufschiene Alu eloxiert, gelocht, zum Aufschrauben	2500 mm	053.3247.250
Double running track aluminium anodized, pre-drilled, surface mounted	3500 mm	053.3247.350
Rail de roulement double en alu anodisé, perforé, à visser en applique	6000 mm	053.3247.600

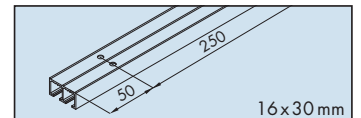

F Doppelaufschiene Alu, gelocht, zum Schrauben	2500 mm	053.3248.250
Double running track aluminium, pre-drilled, for screw fixing	3500 mm	053.3248.350
Rail de roulement double en alu, perforé, à visser	6000 mm	053.3248.600

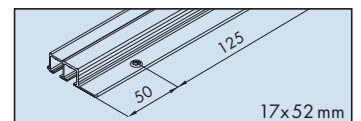

Penloc GTI, Kleber

Penloc GTI, adhesive

Penloc GTI, colle

098.0026.000

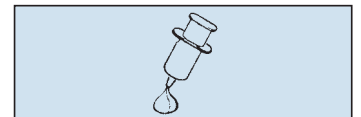

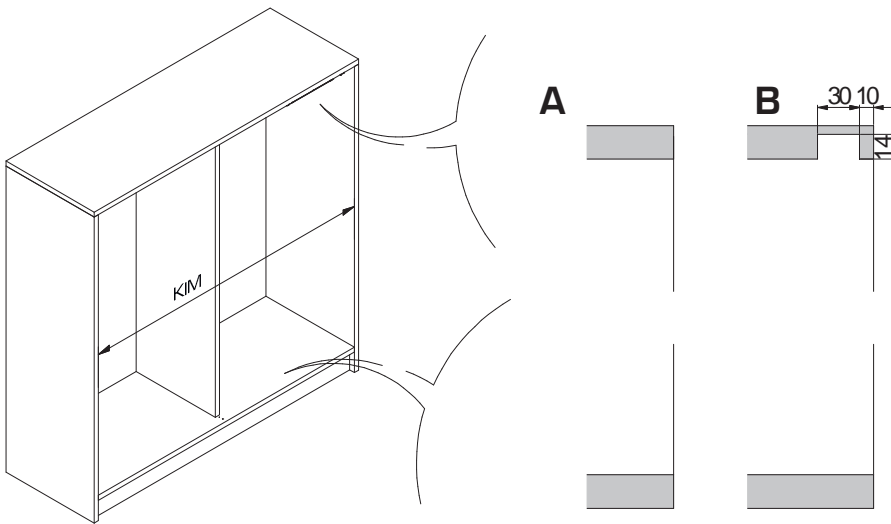

A

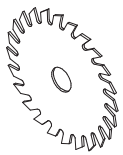

A Art.No. 053.3247

B Art.No. 053.3248

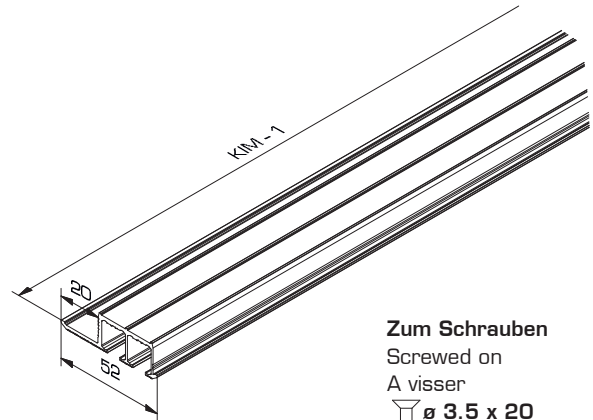
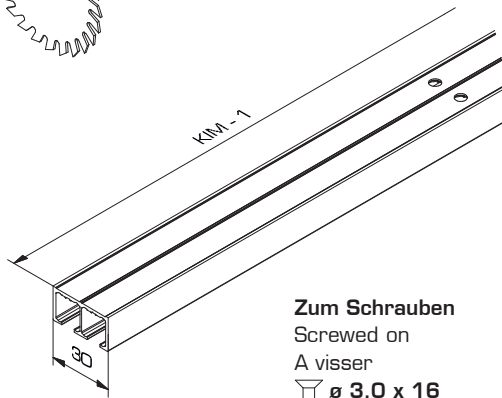

B 1

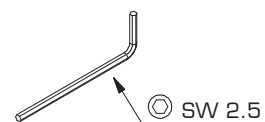
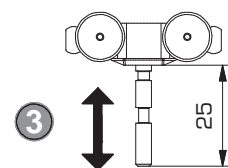
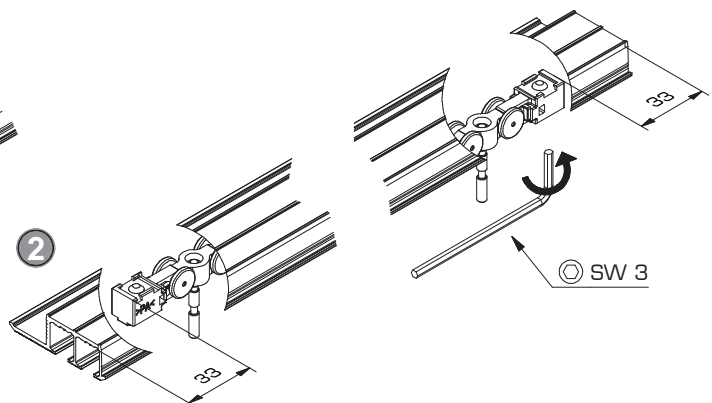
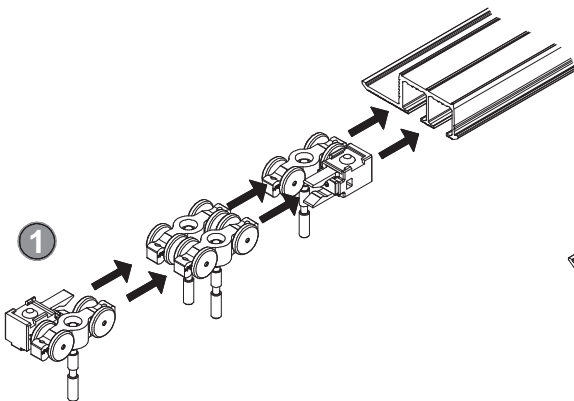

B 2

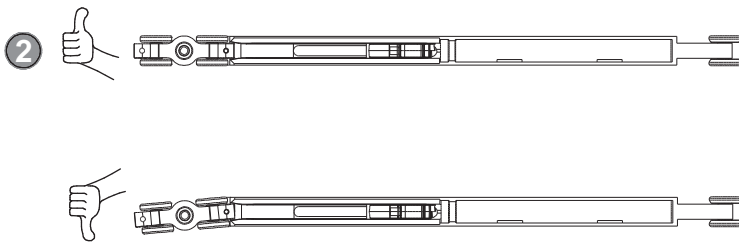
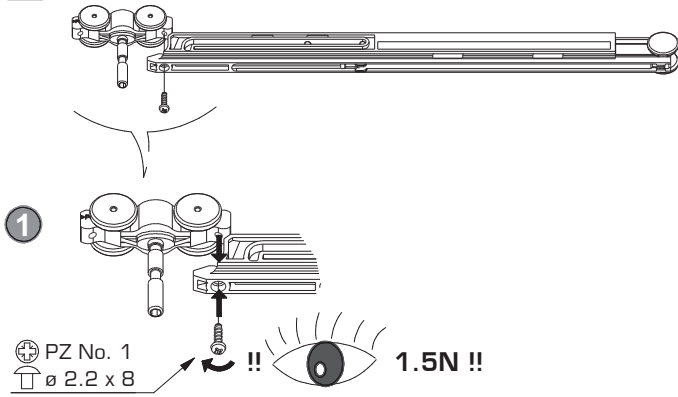

C

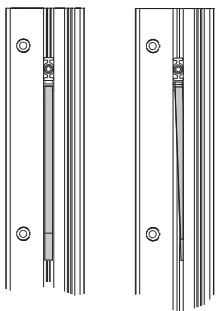
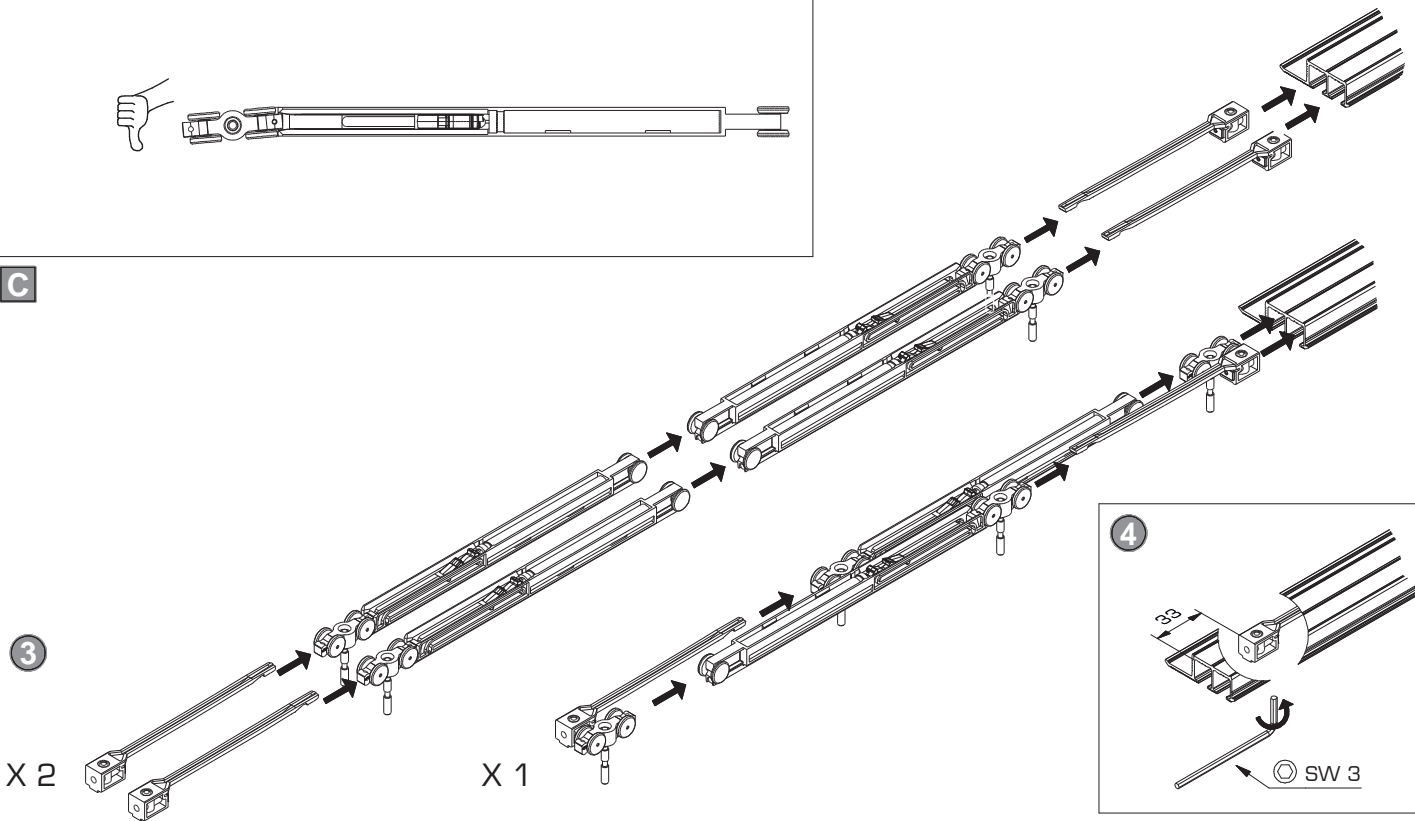

		* Bestellen / order / commander - 16 kg	
X 1	Dämpfen in Schliessrichtung Soft closing function in closing direction Amortissement dans le sens de fermeture	min. 260mm	1x 053.3332.072
X 2	Dämpfen in Schliess- und Öffnungsrichtung Soft closing function in opening and closing direction Amortissement dans le sens de fermeture et d'ouverture	min. 460mm	2x 053.3332.072

Empfehlung: Der Zugang zu den Dämpfungskomponenten sollte jederzeit möglich sein.
Demontierbare Laufschielen oder Möbelkonstruktion entsprechend planen.

Recommendation: The access to soft-closing components should be possible at any time. Plan removable running tracks or furniture designs accordingly.

Recommandation: L'accès aux composants de l'amortisseur doit être possible é tout moment. Prévoir en conséquence des rails de roulement ou une constructions de meuble démontables

Garnituren / Sets / Garnitures

No. 053.3332.XXX	
	2x
	2x
	2x

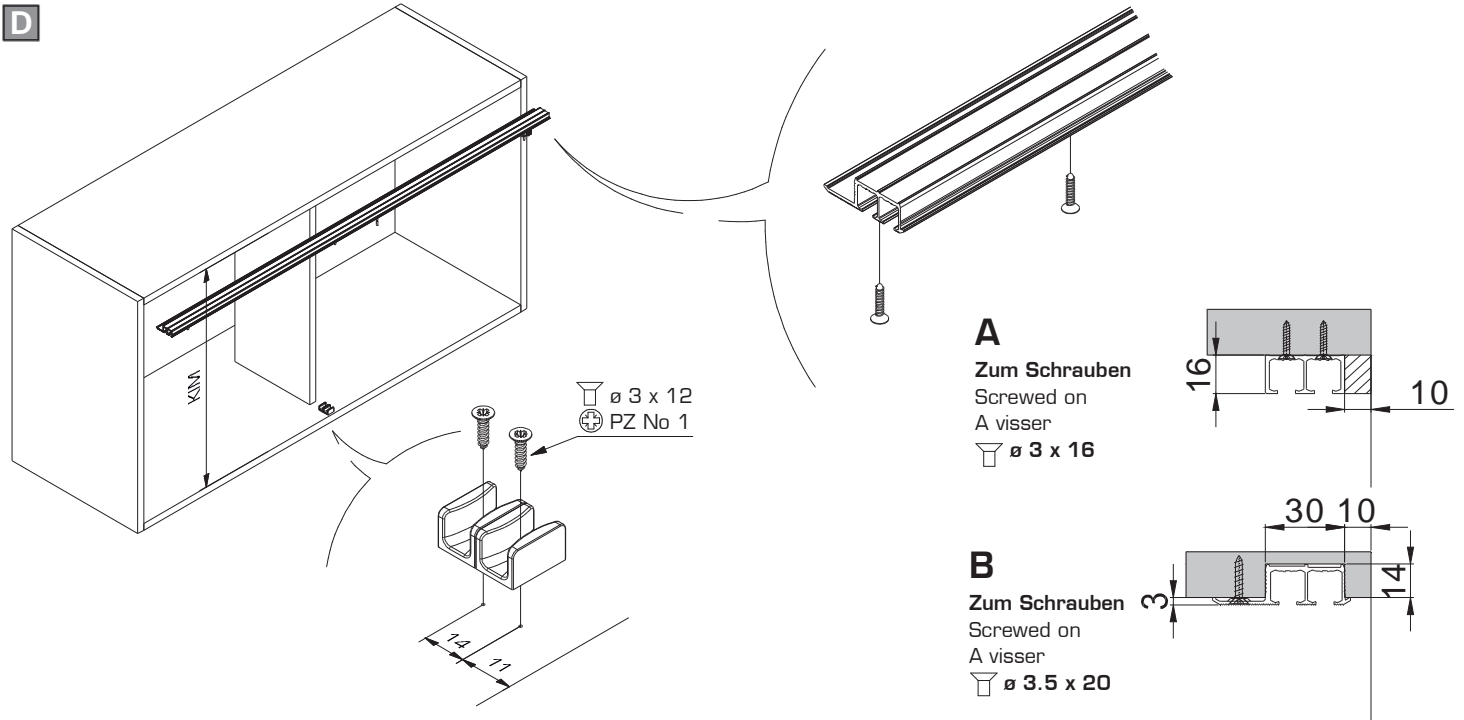

A: *TH = KIM - 22

B: *TH = KIM - 9

A+B: **TB = $\frac{KIM + 16}{2}$

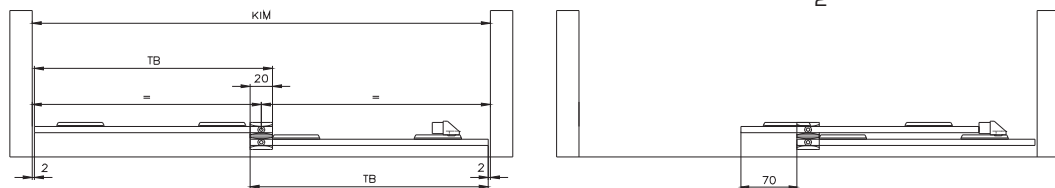

E Kleben | Glue | Coller



Klebstoff-Empfehlung:
Recommended adhesive:
Colle recommandée:
Penloc GTI
Art.No. 098.0026.000

Nur bei keramischem Siebdruck!
Only ceramic screen printing!
Sulement pour verre serigraphie céramique!

1

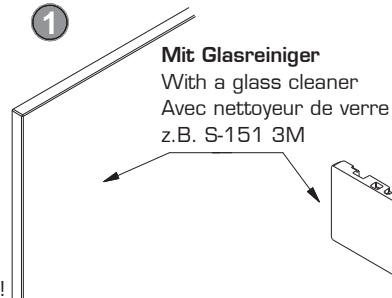

2



3

Offene Zeit < 2min.
open time < 2min.
temps ouvert < 2min.

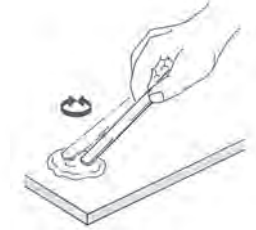

4



5

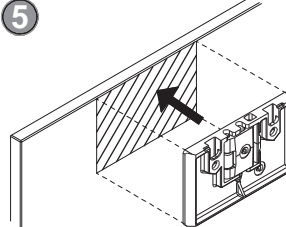

6



7

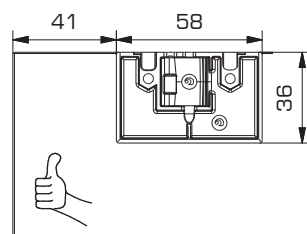

Bündig mit Glaskante
Flush with glass edge
Affleurant avec verre découpé

8



9



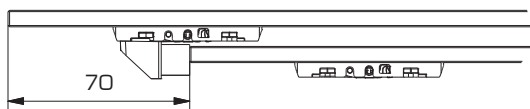
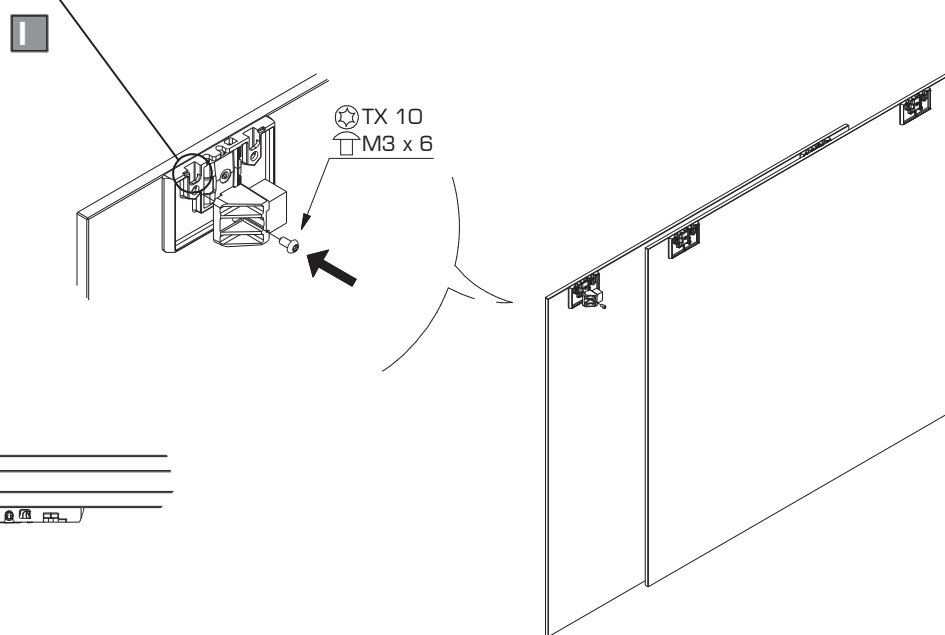
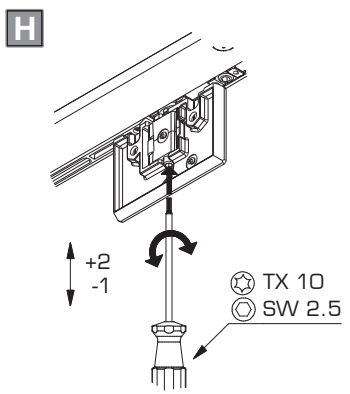
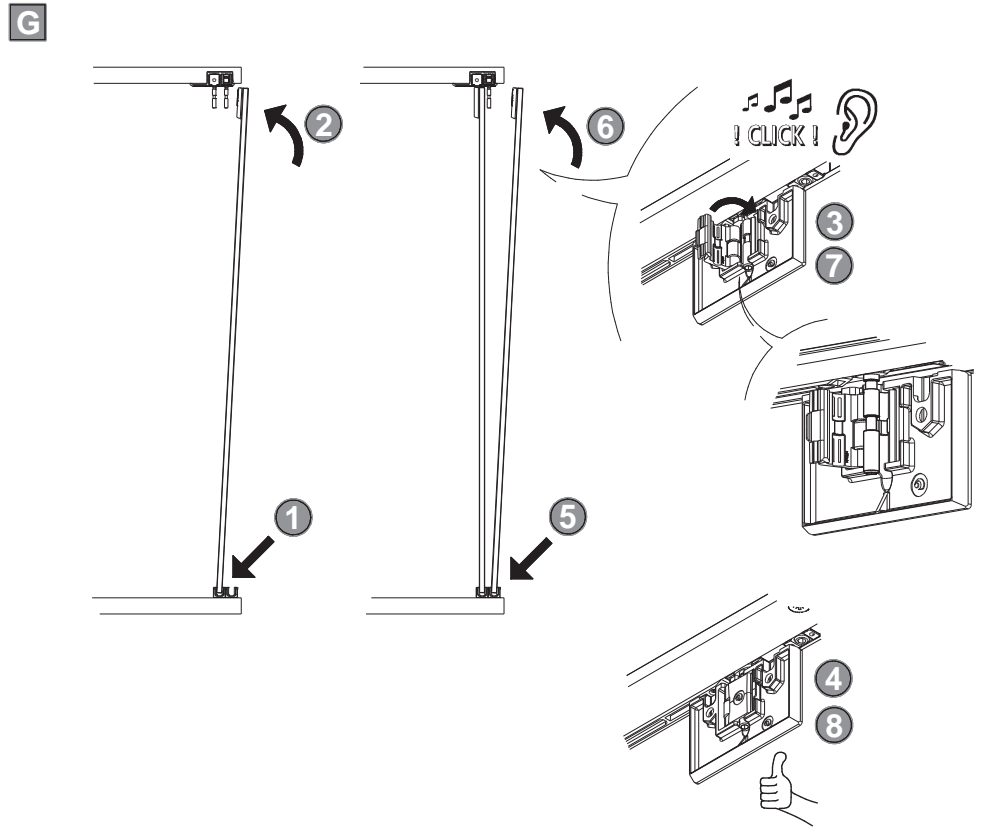
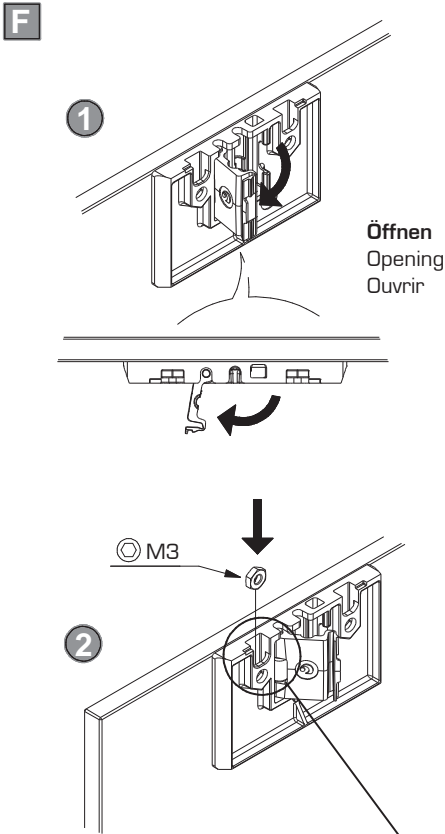

J Türdemontage
Door dismantling
Demontage de la porte

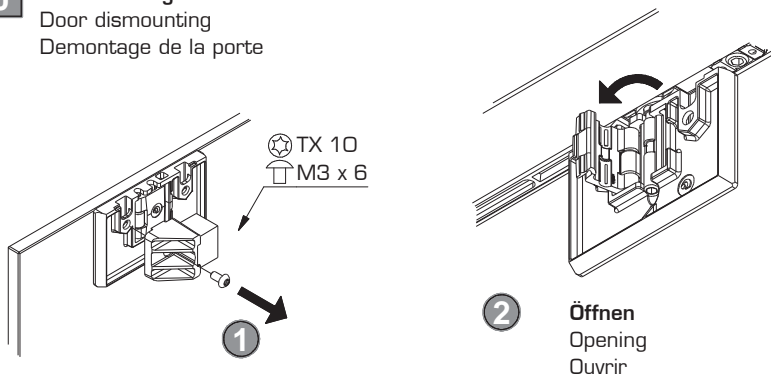

Einbaubeispiele | Mounting examples | Exemples de montage

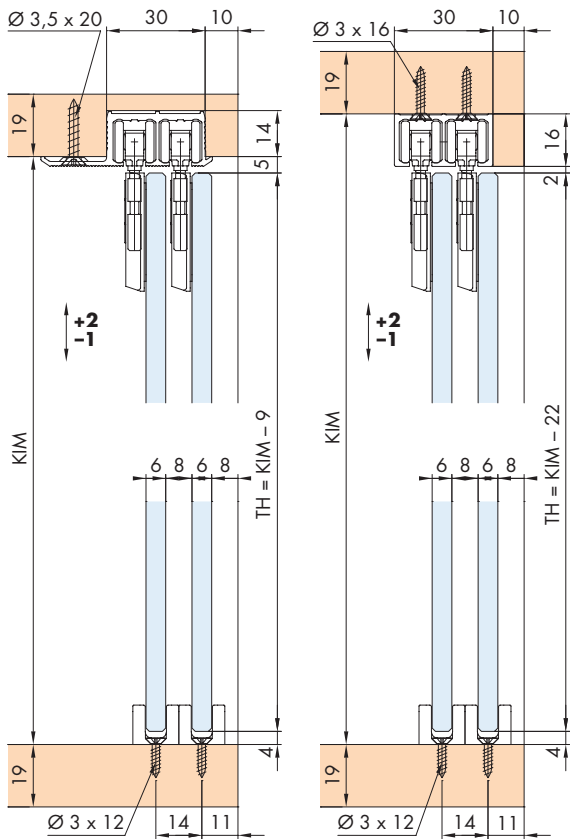

Wichtig/Important/Important

Beschlag einsetzbar mit ESG Floatglas, ESG Satinato, ESG mit keramischem Siebdruck, Doppelspiegel oder VSG Gläser.

(ESG = Einscheibensicherheitsglas / VSG = Verbund-sicherheitsglas)

Fitting can be used in combination with ESG float glass, ESG satinato glass, ESG with ceramic screen printing, double mirror or laminated glass.

(ESG = tempered safety glass)

Ferrure utilisable avec vitre flottée de sécurité ESG, vitre de sécurité ESG Satinato, vitre de sécurité ESG avec sérigraphie céramique, miroir double ou vitres feuilletées.

(ESG = verre de sécurité trempé)

Klebstoff-Empfehlungen:

Recommended adhesive

Colle recommandée

- **PENLOC TYP GTI / GZH**

66

