

Corner bench hinge

For wooden seat panels



> No separate hinge connection required



- > Opening angle: 95°
- > Area of application: Joint designed for safe lift-up of seat panel
- > Material: Steel
- > Finish: Blue galvanized
- > Opening angle res-
traint: The opening stop in the hinge joint prevents the seat panel from butting against the fitting
- > Large swivel range to the front (110 mm) allows lifting up seat panels even with thick padding
- > A gap between seat panel and backrest is not required
- > The springs for panel weight 8 kg or 12 kg provide optimum weight compensation and allow opening with ease



Installation

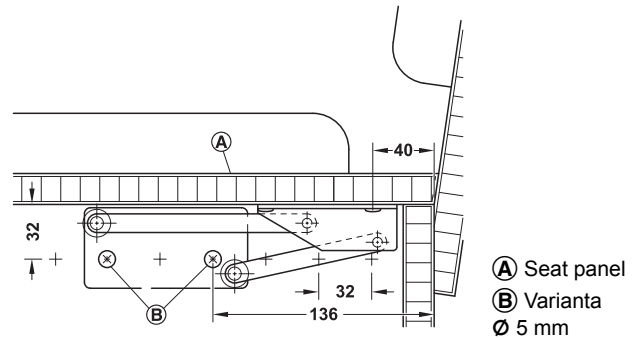
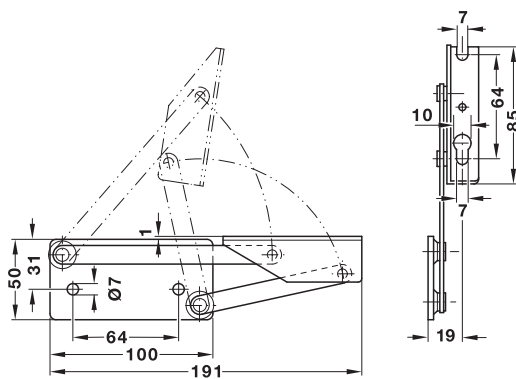

- Ⓐ Seat panel
- Ⓑ Varianta
- ∅ 5 mm

→ Without spring For lightweight seat panels

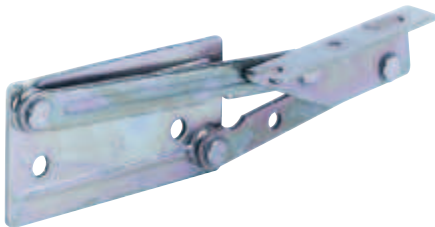

Suitable for	Cat. No.
Lightweight seat panels	643.01.500
Packing: 1 or 10 pairs	

→ With spring For panel weights up to 8 kg or up to 12 kg



Suitable for	Cat. No.
Panel weight up to 8 kg	643.01.516
Panel weight up to 12 kg	643.01.525
Packing: 1 or 10 pairs	