

Monitor support Häfele Officys MA 11

With one arm

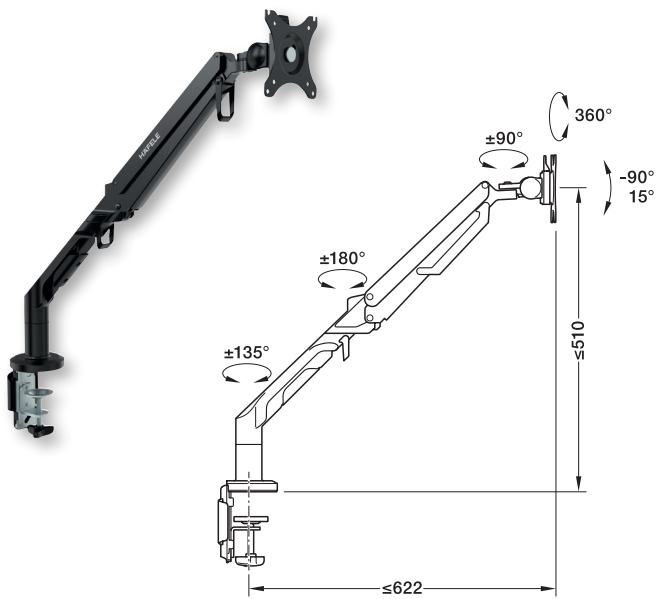

- > Area of application: For clamp fixing to table top thickness 20–100 mm or secured through hole in table top thickness 25–100 mm
- > Material: Top arm and VESA plate: Steel, Bottom arm and base: Aluminium, Cable guide: Plastic
- > Colour/finish: Black
- > For screen size: 17–36"
- > VESA standard: 100 x 100 mm, 75 x 75 mm
- > Swivelling range: -90–90°
- > Adjustment facility: Height adjustment: Continuous, Tilt adjustment: -90–15°, Rotates through 360°
- > Cable guide: With clip system in desk pole and monitor arm

Supplied with

- 1 Swivel arm
- 1 Desk pole for clamp fixing
- 1 Desk pole for securing through hole in desktop

Load bearing capacity	Cat. No.
3–12 kg, continuous weight adjustment	818.71.300

Packing: 1 Piece

Monitor support Häfele Officys MA 12

With two arms

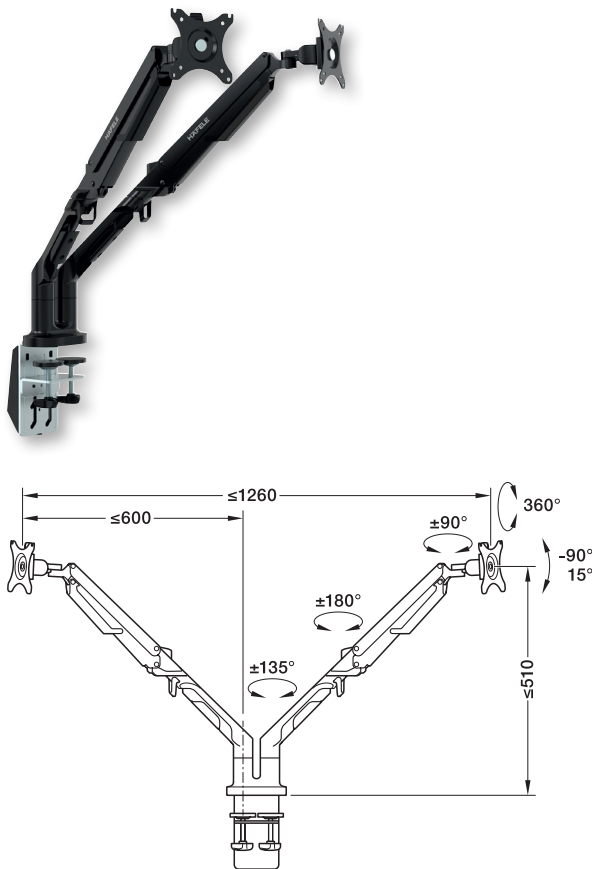

- > Area of application: For clamp fixing to table top thickness 20–120 mm or secured through hole in table top thickness 25–100 mm
- > Material: Top arm and VESA plate: Steel, Bottom arm and base: Aluminium, Cable guide: Plastic
- > Colour/finish: Black
- > For screen size: 17–32"
- > VESA standard: 100 x 100 mm, 75 x 75 mm
- > Swivelling range: -90–90°
- > Adjustment facility: Height adjustment: Continuous, Tilt adjustment: -90–15°, Rotates through 360°
- > Cable guide: With clip system in desk pole and monitor arm

Supplied with

- 2 Swivel arms
- 1 Desk pole for clamp fixing
- 1 Desk pole for securing through hole in desktop

Load bearing capacity	Cat. No.
2–9 kg, per arm, continuous weight adjustment	818.71.310

Packing: 1 Piece