

→ Load bearing capacity 80 kg

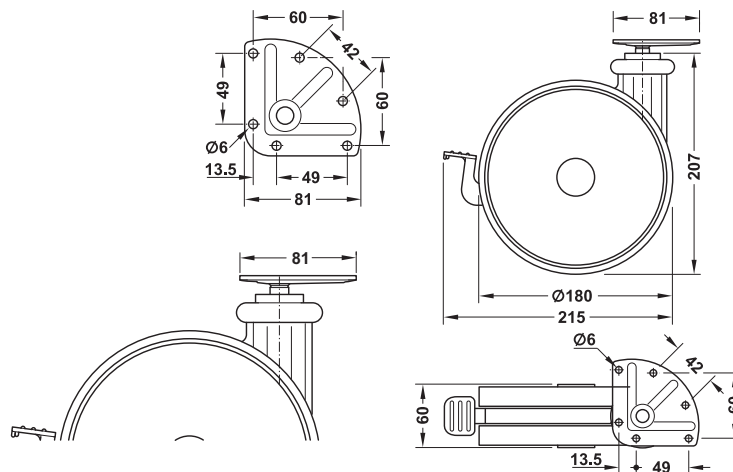

Free running, with brake Free running



With screw-on plate, steel, galvanized Free running, with brake

- > Material: Housing and wheel: Plastic
- > Finish/colour: Housing: Aluminium coloured, wheel: Black, brake: Black
- > Wheel Ø: 180 mm
- > Load bearing capacity: Approx. 80 kg/castor

Installation	Installation height mm	Running surface	Cat. No.
Free running, with brake			
Screw-on plate	215	Hard	661.92.911
Free running			
Screw-on plate	215	Hard	661.92.901

Packing: 2 pieces

→ Load bearing capacity 110 kg

For screw fixing



Free running, with brake



Free running

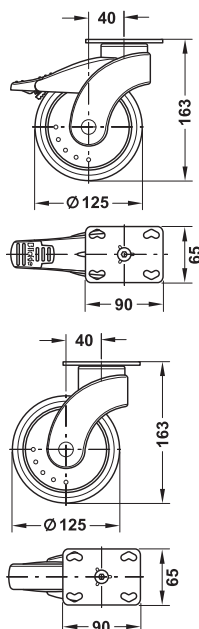

Extremely smooth running action and easy rolling, will not leave marks

- > Material: Housing: Polyamide, running surface: Thermoplastic rubber
- > Colour: Housing: Grey white, RAL 9002, running surface: Grey
- > Version: Brake stops wheel rotation at ring mount, with ball bearings in ring mount and axle bearing, with thread guards, with soft running surface, free running, without fixing material
- > Installation height: 163 mm
- > Wheel Ø: 125 mm
- > Wheel width: 32 mm
- > Load bearing capacity: Approx. 110 kg
- > Installation: For screw fixing with screw-on plate

Note

This castor type is also available in other versions on request:

- > Wheel Ø 100 mm
- > Rust proof stainless steel metal parts
- > All versions also available electrically conductive
- > All versions also available with threaded pin or fastening pin

Installation	Running surface	Cat. No.
Free running, with brake		
For screw fixing with screw-on plate	Soft	661.85.511
Free running		
For screw fixing with screw-on plate	Soft	661.86.511

Packing: 1 piece

DGH-M 2021, HDE-en, 1/120; Dimensional data not binding. We reserve the right to alter specifications without notice.

